



Automatic Dropping Devices (ADD Systems)

Pantograph with spindle drive

ADD-System by Spring Release

The pantograph type Fb can be equipped optionally with an automatic dropping device (ADD-System). The aim of this automatic dropping device is to minimise the risk of a bigger consequential damage to the overhead wire and the pantograph. However, due to the different causes also the types of damages are in such a case very different, so that the risk indeed is minimised, but a damage cannot always be excluded.

Components description of the automatic dropping device

The actuating device for the automatic dropping device is placed in the pantograph collector head and mechanically connects the original automatic dropping device of the pantograph by means of a Bowden cable.

The original automatic dropping device is the prolongation of the main tension spring at the frame of the pantograph.

The following components are installed for the automatic dropping device at the collector head:

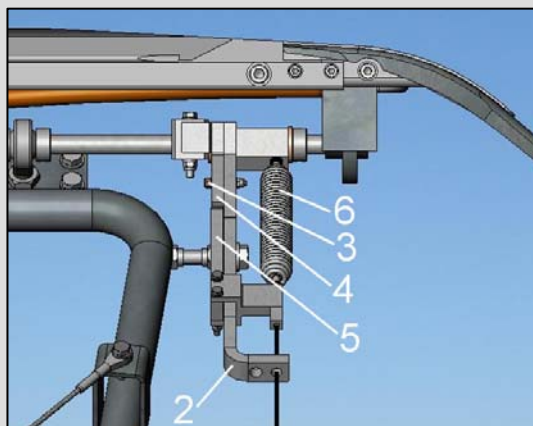

- 1 Bowden cable for actuating the automatic dropping device
- 2 pick-up plate for the upper guide rod
- 3 shear pin
- 4 welded shear piece with pick-up for the shear pin
- 5 slide piece
- 6 tension spring

collector head with automatic dropping device



Automatic Dropping Devices (ADD Systems)

Pantograph with spindle drive

ADD-System by Spring Release

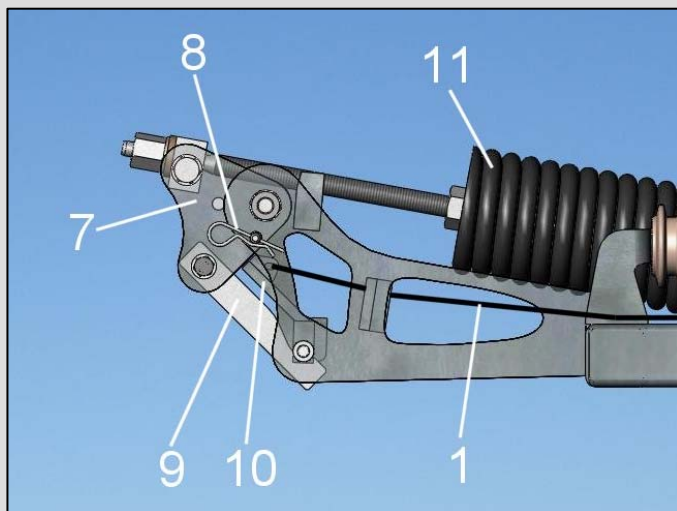

with securing ring

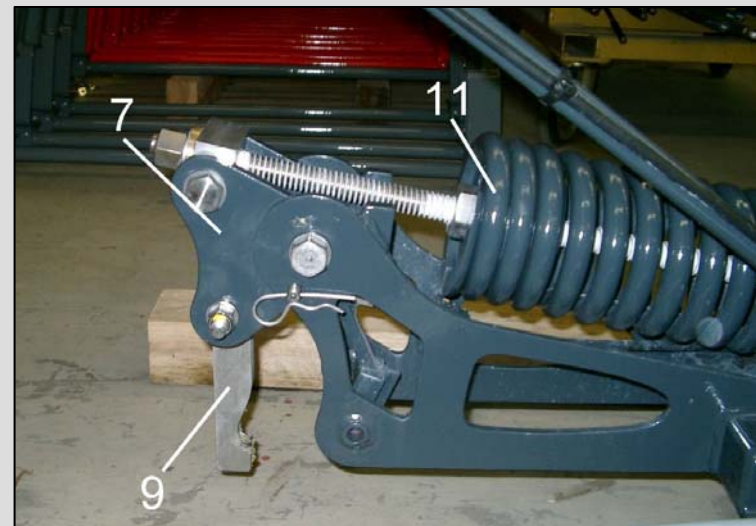

released state

The following components are assigned to the original automatic dropping device in the pantograph frame:

7 triangular lever

8 securing pin (during operation of the vehicle the securing pin is removed and is located lateral at the frame!)

9 latch

10 lever

11 main tension spring



Automatic Dropping Devices (ADD Systems)

Pantograph with spindle drive

ADD-System by Spring Release

Operation of the automatic dropping device

The collector head of the pantograph is beared in a rotating way, but is intentionally restricted in its movement by means of the guide rod block. Easy shocks and irregularities in the overhead wire (e.g. at overhead wire-crossings) are compensated by means of the free-wheeling.

If a failure occurs during operation of the railway vehicle which exceeds the loading of the collector head (e.g. during contact with an obstacle) the automatic dropping device is actuated by the Bowden cable.

The actuation of the automatic dropping device causes the following steps automatically to be effected one after the other:

- A shear pin (item 3) is placed at the pantograph collector head, this pin restricts the rotating movement of the collector head. If the pantograph hits an obstacle this shear pin is ripped off so that the pantograph collector head (incl. the welded shear pieces, item 4) can move freely and if necessary can turn over.
- Due to the movement of the welded shear piece (item 4) a Bowden cable (item 1), which is fastened to it, is tensioned.
- The other end of the Bowden cable is attached to a lever (item 10) of the automatic dropping device. Is the Bowden cable (and thus the lever) being tensioned for several millimetres, a latch (item 9) is released .
- The tensioned main tension spring (item 11) of the pantograph now can freely release whereby the contact of the collector head to the overhead line is interrupted and the pantograph abruptly lowers.
- The main tension spring now is partly released so that the remaining force reduces the free fall of the pantograph on the verge of arriving in lowest position.