

ORDER / FÖRFRÅGAN ORDER / ENQUIRY

Commutator

From _____

Fax No. _____

Motor fabrikat

Motor brand _____

Motor typ

Motor type _____

Gjuten / molded

V-Ringad / build up

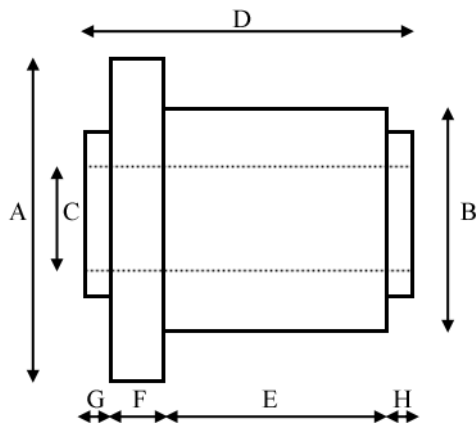

Antal lameller

No of segments _____

A Dia nedledarhals

A Dia over Risers _____

B Dia Borstbana

B Dia over brushtrack _____

C Dia centrumhål

C Dia of Bore _____

D Total längd

D Length Overall _____

E Längd borstbana

E Length Brush Track _____

F Bredd nedledarhalsar

F Width of Risers _____

G Bredd inre isolering

G Width of Rear Extn _____

H Bredd yttre isolering

H Width of Front Extn _____

J Bredd nedledarspår

J Riser Sloth Width _____

K Djup nedledarspår

K Riser Sloth Depth _____

L Kilspår

L Keyway alignment _____

Tätning

Sealing _____

Märkspänning

Working Voltage _____

Önskat antal

Quantity _____

Leveranstid

Delivery req. _____

Temperatur på kommutatorn under normal drift / Working temperature minimum _____

Temperatur på kommutatorn under hög belastning / Working temperature maximum _____

Nedledare

Type of Risers

Förtenta
Tinned

Oförtenta
Not tinned

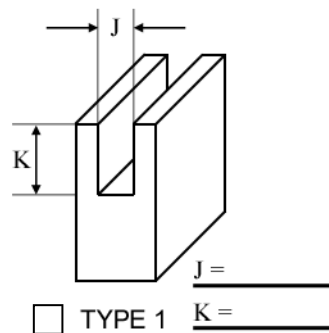

TYPE 1 J = _____
K = _____

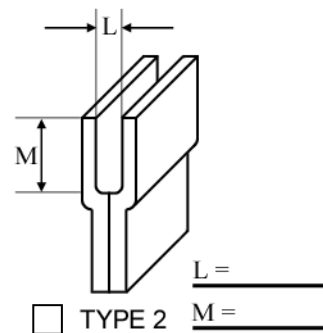

TYPE 2 L = _____
M = _____

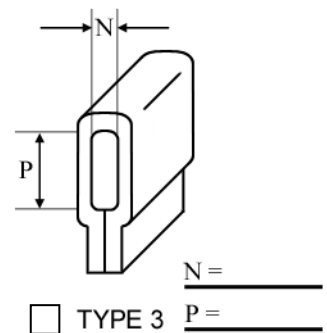

TYPE 3 N = _____
P = _____

Underskrift / Signature _____

Datum / Date _____

Vi levererar också kommutatorer ombyggda på befintliga nav.

Formulär för Släpningar VÄND!

ORDER / FÖRFRÅGAN ORDER / ENQUIRY

Slip rings

From _____

Fax No. _____

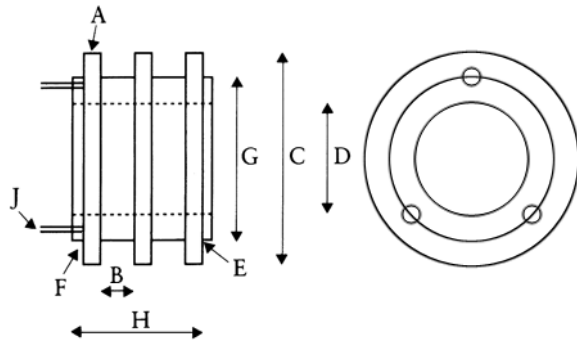

Antal ringar

No of rings _____

A Bredd ringar

A Width of rings _____

B Avstånd mellan ringar

B Distance between rings _____

C Diameter ringar

C Diameter of rings _____

D Diameter centrumhål

D Diameter of bore _____

E Bredd isolering efter sista ring

E Width of rear extrusion _____

F Bredd isolering anslutningsida

F Width of front extrusion _____

G Diameter isolering

G Diameter of insulation _____

H Total längd

H Overall length _____

J Storlek anslutning (typ M6)

J Stud size _____

Märkspänning

Working Voltage _____

Max hastighet

Max speed _____

Önskat antal

Quantity _____

Leveranstid

Delivery req. _____

OBS!

Remarks _____

Underskrift / Signature _____ Datum / Date _____